



ZERO EMISSIONS POWERTRAINS

Product catalogue 2023





Technical specifications

Urbino 9 LE electric	03
Urbino 15 LE electric	04
Urbino 12 electric	05
Urbino 18 electric	06
Urbino 24 electric	07
Urbino 12 hydrogen	08
Urbino 18 hydrogen	09
Trollino 12	10
Trollino 18	11
Trollino 24	12

Technical drawings

Urbino 9 LE electric	13
Urbino 15 LE electric	13
Urbino 12 electric	13
Urbino 18 electric	13
Urbino 12 hydrogen	14
Urbino 18 hydrogen	14
Trollino 12	15
Trollino 18	15
Trollino 24	15
Trollino 24 Metrostyle	16

Photos

[17 - 24](#)

More: www.solarisbus.com

Urbino 9 LE electric

- standard
- option

Driveline	Motor (maximum power)	
	Synchronous motor 220 kW	●
	Traction batteries	
	lithium-ion (capacity depending on specification)	●
	operation up to 24h (depending on batteries capacity and charging system)	●
	Charging system	
	plug-in	●
	pantograph	○
Chassis	Front axle	
	ZF independent suspension	●
	Drive axle	
	DANA rigid axle	●
	Central lubrication	
	central lubrication point - solid lubricating grease	●
	central lubrication system with self-diagnostic - semi-fluid lubrication grease	○
	Steering system	
	RB Servocom	●
	Braking system	
EBS (Electronic Braking System), ABS (Anti-Lock Braking System), ASR (Acceleration Slip Regulation)	●	
ESC (Electronic Stability Control)	○	
Suspension levelling system		
ECAS air suspension with leveling and kneeling function	●	

Urbino 9 LE electric

- standard
- option

Bodywork	Body structure	
	stainless steel	●
	Side panels	
	removable side panels	●
	Door arrangement	1-2
	Entrance height	
	Entrance height for all doors and 265x70R19.5 wheels	320 mm
	Entrance height for all doors and 285x70R19.5 wheels	335 mm
	Wheelchair ramp	
	Wheelchair ramp at the 2nd entrance, manually operated	●
	Wheelchair ramp at the 2nd entrance, operated	○
	Number of passenger seats (depending on equipment)	max. 31
Heating, ventilation and air-conditioning	Air-conditioning in the driver's cabin	
	air-conditioning powered by passenger compartment unit	○
	Air-conditioning in the passenger compartment	
	air-conditioning with electrical drive	○
	air-conditioning with CO ₂ heat pump	○
	Ventilation system	
	dual-function fans	○
Electrical installation	Electrical installation	
	electrical installation based on CAN-Bus system	●

Urbino 15 LE electric

- standard
- option

Driveline	Motor (maximum power)	
	asynchronous motor 280 kW	●
	asynchronous motor 300 kW	○
	Traction batteries	
	lithium-ion (capacity depending on specification)	●
	operation up to 24h (depending on batteries capacity and charging system)	●
Charging system		
	plug-in	●
	pantograph	○
Chassis	Front axle	
	ZF independent suspension	●
	Drive axle	
	ZF portal axle	●
	Tag axle	
	ZF tag axle	●
	ZF tag axle with active steering	○
	Central lubrication	
	central lubrication point - solid lubricating grease	●
	central lubrication system with self-diagnostic - semi-fluid lubrication grease	○
	Steering system	
	RB Servocom	●
Braking system		
EBS (Electronic Braking System), ABS (Anti-Lock Braking System), ASR (Acceleration Slip Regulation)	●	
ESC (Electronic Stability Control)	○	
Suspension levelling system		
ECAS air suspension with leveling and kneeling function	●	

Urbino 15 LE electric

- standard
- option

Bodywork	Body structure	
	stainless steel	●
	Side panels	
	removable side panels	●
	Door arrangement	
		1-2-0 2-2-0 1-2-1 2-2-1
Entrance height		
	Entrance height for all doors and 275x70R22.5 wheels	320 mm
	Entrance height for all doors and 295x80R22.5 wheels	360 mm
Wheelchair ramp		
Wheelchair ramp at the 2nd entrance, manually operated	●	
Wheelchair ramp at the 2nd entrance, operateed	○	
Number of passenger seats (depending on door arrangement and batteries)		max. 65
Heating, ventilation and air-conditioning	Air-conditioning in the driver's cabin	
	air-conditioning powered by passenger compartment unit	○
	air-conditioning with electric drive	○
	Air-conditioning in the passenger compartment	
	air-conditioning with electrical drive	○
	air-conditioning with CO ₂ heat pump	○
Ventilation system		
dual-function fans	●	
Electrical installation	Electrical installation	
	electrical installation based on CAN-Bus system	●

Urbino 12 electric

- standard
- option

Driveline	Motor (maximum power)	
	asynchronous motor 160 kW	○
	asynchronous motor 200 kW	●
	electric portal axle ZF AVE130 2x125 kW	○
	Traction batteries	
	lithium-ion (capacity depending on specification)	●
	operation up to 24h (depending on batteries capacity and charging system)	●
	Charging system	
	plug-in	●
	pantograph	○
Chassis	Front axle	
	ZF independent suspension	●
	ZF rigid axle	○
	Drive axle	
	ZF portal axle	○
	ZF portal axle with integrated electric motors	●
	Central lubrication	
	central lubrication point - solid lubricating grease	●
	central lubrication system with self-diagnostic - semi-fluid lubrication grease	○
	Steering system	
	RB Servocom	●
	Braking system	
	EBS (Electronic Braking System), ABS (Anti-Lock Braking System), ASR (Acceleration Slip Regulation)	●
ESC (Electronic Stability Control)	○	
Suspension levelling system		
ECAS air suspension with leveling and kneeling function	●	

Urbino 12 electric

- standard
- option

Bodywork	Body structure	
	stainless steel	●
	Side panels	
	removable side panels	●
	Door arrangement	1-2-0 2-2-0 1-2-2 2-2-2
	Entrance height	
	entrance height for all doors and 275x70R22.5 wheels	320 mm
	Wheelchair ramp	
	Wheelchair ramp at the 2nd entrance, manually operated	●
	Wheelchair ramp at the 2nd entrance, operated	○
Number of passenger seats (depending on door arrangement and batteries)	max. 39 + 4	
Heating, ventilation and air-conditioning	Air-conditioning in the driver's cabin	
	air-conditioning powered by passenger compartment unit	○
	air-conditioning with electric drive	○
	Air-conditioning in the passenger compartment	
	air-conditioning with electrical drive	○
	air-conditioning with CO ₂ heat pump	○
Ventilation system		
dual-function fans	●	
Electrical installation	Electrical installation	
	electrical installation based on CAN-Bus system	●

Urbino 18 electric

- standard
- option

Driveline	Motor (maximum power)	
	asynchronous motor 240 kW	●
	electric portal axle ZF AVE130 2x125 kW (*)	○
	Traction batteries	
	lithium-ion (capacity depending on specification)	●
	operation up to 24h (depending on batteries capacity and charging system)	●
	Charging system	
plug-in	●	
pantograph	○	
Chassis	Front axle	
	ZF independent suspension	●
	ZF rigid axle (*)	○
	Drive axle	
	ZF portal axle	●
	ZF portal axle with integrated electric motors (*)	○
	Central axle	
	ZF neutral axle	●
	Central lubrication	
	central lubrication point - solid lubricating grease	●
	central lubrication system with self-diagnostic - semi-fluid lubrication grease	○
	Steering system	
	RB Servocom	●
Braking system		
EBS (Electronic Braking System), ABS (Anti-Lock Braking System), ASR (Acceleration Slip Regulation)	●	
Suspension levelling system		
ECAS air suspension with leveling and kneeling function	●	

(*) not available in the version with a modular drive

Urbino 18 electric

- standard
- option

Bodywork	Body structure	
	stainless steel	●
	Side panels	
	removable side panels	●
	Door arrangement	
		1-2-2-0
		2-2-2-0
		1-2-2-2
		2-2-2-2
	Entrance height	
entrance height for all doors and 275x70R22.5 wheels	320 mm	
Wheelchair ramp		
Wheelchair ramp at the 2nd entrance, manually operated	●	
Wheelchair ramp at the 2nd entrance, operated	○	
Number of passenger seats (depending on door arrangement and batteries)	max. 52 + 6	
Heating, ventilation and air-conditioning	Air-conditioning in the driver's cabin	
	air-conditioning powered by passenger compartment unit	○
	air-conditioning with electric drive	○
	Air-conditioning in the passenger compartment	
	air-conditioning with electrical drive	○
	air-conditioning with CO ₂ heat pump	○
	Ventilation system	
dual-function fans	●	
Electrical installation	Electrical installation	
	electrical installation based on CAN-Bus system	●

Urbino 24 electric		<input checked="" type="radio"/> standard <input type="radio"/> option
Driveline	Drive system	
	electric portal axle ZF AVE130 2x125 kW	<input type="radio"/>
	Traction batteries	
	lithium-ion batteries (capacity depending on specification)	<input type="radio"/>
	Pantographs	
	manual pantograph	<input type="radio"/>
	semiautomatic or automatic pantograph	<input checked="" type="radio"/>
Chassis	Front axle	
	ZF independent suspension	<input checked="" type="radio"/>
	ZF rigid axle	<input type="radio"/>
	Drive axle	
	ZF portal axle	<input checked="" type="radio"/>
	Central axle	
	ZF neutral axle	<input checked="" type="radio"/>
	Fourth axle	
	ZF tag axle	<input type="radio"/>
	ZF tag axle with active steering	<input checked="" type="radio"/>
	Central lubrication	
	central lubrication point - solid lubricating grease	<input checked="" type="radio"/>
	central lubrication system with self-diagnostic - semi-fluid lubrication grease	<input type="radio"/>
Steering system		
RB Servocom	<input checked="" type="radio"/>	
Braking system		
EBS (Electronic Braking System), ABS (Anti-Lock Braking System), ASR (Acceleration Slip Regulation)	<input checked="" type="radio"/>	
Suspension levelling system		
ECAS air suspension with leveling and kneeling function	<input checked="" type="radio"/>	

Urbino 24 electric		<input checked="" type="radio"/> standard <input type="radio"/> option
Bodywork	Body structure	
	stainless steel	<input checked="" type="radio"/>
	Side panels	
	removable side panels	<input checked="" type="radio"/>
	Door arrangement	1-2-2-2-0 1-2-2-2-2
	Entrance height	
	entrance height for all doors	320 mm
	Wheelchair ramp	
	wheelchair ramp at the 2nd entrance, manually operated	<input checked="" type="radio"/>
	wheelchair ramp at the 2nd entrance, electrically operated	<input type="radio"/>
Number of passenger seats (depending on door arrangement and batteries)	max. 68	
Heating, ventilation and air-conditioning	Air-conditioning in the driver's cabin	
	air-conditioning powered by passenger compartment unit	<input type="radio"/>
	air-conditioning with electric drive	<input type="radio"/>
	Air-conditioning in the passenger compartment	
	air-conditioning with electrical drive	<input type="radio"/>
	Ventilation system	
dual-function fans	<input checked="" type="radio"/>	
Passenger compartment heating system		
electric 1-stage blowers	<input type="radio"/>	
water heating, electric water heater TJ40.3 (40 kW), convector-type heaters, 2-stage blowers	<input checked="" type="radio"/>	
Electrical installation	Electric installation	
electrical installation based on Can-Bus system	<input checked="" type="radio"/>	

Urbino 12 hydrogen

● standard
○ option

Driveline	Motor (maximum power)	
	electric portal axle ZF AVE130 2x125 kW	●
	asynchronous motor 240 kW	○
	Hydrogen fuel cell	
	70kW	●
	Traction batteries	
	lithium-ion	●
Hydrogen tanks		
composite tanks 5 x 312 l	●	
Charging system		
plug-in	●	
Chassis	Front axle	
	ZF independent suspension	●
	Drive axle	
	ZF portal axle with integrated electric motors	●
	ZF portal axle	○
	Central lubrication	
	central lubrication point - solid lubricating grease	●
	central lubrication system with self-diagnostic - semi-fluid lubrication grease	○
	Steering system	
	RB Servocom	●
	Braking system	
EBS (Electronic Braking System), ABS (Anti-Lock Braking System), ASR (Acceleration Slip Regulation)	●	
ESC (Electronic Stability Control)	○	
Suspension levelling system		
ECAS air suspension with leveling and kneeling function	●	

Urbino 12 hydrogen

● standard
○ option

Bodywork	Body structure	
	stainless steel	●
	Side panels	
	removable side panels	●
	Door arrangement	
		1-2-0
		2-2-0
		1-2-2
		2-2-2
	Entrance height	
entrance height for all doors	320 mm	
Wheelchair ramp		
wheelchair ramp at the 2nd entrance, manually operated	●	
wheelchair ramp at the 2nd entrance, electrically operated	○	
Number of passenger seats (depending on door arrangement and batteries)	max. 37 + 4	
Heating, ventilation and air-conditioning	Air-conditioning in the driver's cabin	
	air-conditioning powered by passenger compartment unit	●
	Air-conditioning in the passenger compartment	
air-conditioning with electrical drive	○	
air-conditioning with CO ₂ heat pump	●	
Electrical installation	Electrical installation	
electrical installation based on CAN-Bus system	●	

Urbino 18 hydrogen ● standard
○ option

Drivetrain system	Motor (maximum power)	
	electric portal axle ZF AVE130 2x125 kW	○
	asynchronous motor 240 kW	●
	Hydrogen fuel cell	
	100kW	●
	Traction batteries	
	lithium-ion	●
	Hydrogen tanks	
	composite tanks 5 x 312 l	●
	composite tanks 3 x 190 l	●
Hydrogen refilling port		
Above the 1st right wheel arch	●	
Above both sides of the 1st wheel arch	○	
Above the 1st left 1st wheel arch	○	
Charging system		
plug-in	●	

Chassis	Front axle	
	ZF independent suspension	●
	Drive axle	
	ZF portal axle with integrated electric motors	○
	ZF portal axle	●
	Central axle	
	ZF neutral axle	●
	Central lubrication	
	central lubrication point - solid lubricating grease	●
	central lubrication system with self-diagnostic - semi-fluid lubrication grease	○
Steering system		
RB Servocom	●	

Urbino 18 hydrogen ● standard
○ option

Braking system	
EBS (Electronic Braking System), ABS (Anti-Lock Braking System), ASR (Acceleration Slip Regulation)	●
Suspension levelling system	
ECAS air suspension with leveling and kneeling function	●

Bodywork	Body structure	
	stainless steel	●
	Side panels	
	removable side panels	●
	Door arrangement	
		1-2-2-0 2-2-2-0 1-2-2-2 2-2-2-2
	Entrance height	
	entrance height for all doors	320 mm
	Wheelchair ramp	
	wheelchair ramp at the 2nd entrance, manually operated	●
wheelchair ramp at the 2nd entrance, electrically operated	○	
Number of passenger seats (depending on door arrangement and batteries)	max. 52 + 6	

Heating, ventilation and air-conditioning	Air-conditioning in the driver's cabin	
	air-conditioning powered by passenger compartment unit	●
	Air-conditioning in the passenger compartment	
air-conditioning with electrical drive	○	
air-conditioning with CO ₂ heat pump	●	

Electrical installation	Electrical installation	
	electrical installation based on CAN-Bus system	●

Trollino 12

● standard
○ option

Driveline	Drive system	
	MEDCOM ANT 175-600 (IGBT) asynchronous 175 kW 6-pole motor	○
	MEDCOM ANT 175-600 (IGBT) asynchronous 160 kW 4-pole motor	○
	Škoda BlueDrive (IGBT) asynchronous 160 kW 4-pole motor	○
	Kiepe IMC 500 (IGBT) asynchronous 160 kW 4-pole motor	○
	Traction batteries	
	lithium-ion batteries (capacity depending on specification)	○
Pantographs		
manual pantograph	●	
semiautomatic or automatic pantograph	○	
Chassis	Front axle	
	ZF independent suspension	●
	ZF rigid axle	○
	Drive axle	
	ZF portal axle	●
	Central lubrication	
	central lubrication point - solid lubricating grease	●
	central lubrication system with self-diagnostic - semi-fluid lubrication grease	○
	Steering system	
	RB Servocom	●
	Braking system	
	EBS (Electronic Braking System), ABS (Anti-Lock Braking System), ASR (Acceleration Slip Regulation)	●
	Suspension levelling system	
ECAS air suspension with leveling and kneeling function	●	

Trollino 12

● standard
○ option

Bodywork	Body structure	
	stainless steel	●
	Side panels	
	removable side panels	●
	Door arrangement	
		1-2-0
		2-2-0
		1-2-2
		2-2-2
	Entrance height	
entrance height for all doors	320 mm	
Wheelchair ramp		
wheelchair ramp at the 2nd entrance, manually operated	●	
wheelchair ramp at the 2nd entrance, electrically operated	○	
Number of passenger seats (depending on door arrangement and batteries)	max. 39 + 4	
Heating, ventilation and air-conditioning	Air-conditioning in the driver's cabin	
	air-conditioning powered by passenger compartment unit	○
	air-conditioning with electric drive	○
	Air-conditioning in the passenger compartment	
	air-conditioning with electrical drive	○
	Ventilation system	
	dual-function fans	●
	Passenger compartment heating system	
electric 1-stage blowers	○	
water heating, electric water heater TJ40.3 (40 kW), convector-type heaters, 2-stage blowers	●	
Electrical installation	Electric installation	
	electrical installation based on Can-Bus system	●

Trollino 18

- standard
- option

Driveline	Drive system	
	MEDCOM ANT 250-600 (IGBT) asynchronous 250 kW 6-pole motor	○
	MEDCOM ANT 250-600 (IGBT) asynchronous 240 kW 4-pole motor	○
	Škoda BlueDrive (IGBT) asynchronous 250 kW 6-pole motor	○
	Kiepe IMC 500 (IGBT) 2-axle drive: 2 asynchronous 160 kW 4-pole motors	○
	Traction batteries	
	lithium-ion batteries (capacity depending on specification)	○
Pantographs		
manual pantograph	●	
semiautomatic or automatic pantograph	○	
Chassis	Front axle	
	ZF independent suspension	●
	ZF rigid axle	○
	Drive axle	
	ZF portal axle	●
	Central axle	
	ZF neutral axle	●
	Central lubrication	
	central lubrication point - solid lubricating grease	●
	central lubrication system with self-diagnostic - semi-fluid lubrication grease	○
	Steering system	
	RB Servocom	●
	Braking system	
	EBS (Electronic Braking System), ABS (Anti-Lock Braking System), ASR (Acceleration Slip Regulation)	●
	Suspension levelling system	
ECAS air suspension with leveling and kneeling function	●	

Trollino 18

- standard
- option

Bodywork	Body structure	
	stainless steel	●
	Side panels	
	removable side panels	●
	Door arrangement	1-2-2-0 2-2-2-0 1-2-2-2 2-2-2-2
	Entrance height	
	entrance height for all doors	320 mm
Wheelchair ramp		
wheelchair ramp at the 2nd entrance, manually operated	●	
wheelchair ramp at the 2nd entrance, electrically operated	○	
Number of passenger seats (depending on door arrangement and batteries)	max. 45 + 8	
Heating, ventilation and air-conditioning	Air-conditioning in the driver's cabin	
	air-conditioning powered by passenger compartment unit	○
	air-conditioning with electric drive	○
	Air-conditioning in the passenger compartment	
	air-conditioning with electrical drive	○
	Ventilation system	
	dual-function fans	●
Passenger compartment heating system		
electric 1-stage blowers	○	
water heating, electric water heater TJ40.3 (40 kW), convector-type heaters, 2-stage blowers	●	
Electrical installation	Electric installation	
	electrical installation based on Can-Bus system	●

Trollino 24 ● standard
○ option

Driveline	Drive system	
	Škoda BlueDrive (IGBT) asynchronous 160 kW 4-pole motor	○
	Traction batteries	
	lithium-ion batteries (capacity depending on specification)	○
	Pantographs	
	manual pantograph	○
	semiautomatic or automatic pantograph	●

Chassis	Front axle	
	ZF independent suspension	●
	ZF rigid axle	○
	Drive axle	
	ZF portal axle	●
	Fourth axle	
	ZF tag axle	○
	ZF tag axle with active steering	●
	Central lubrication	
	central lubrication point - solid lubricating grease	●
central lubrication system with self-diagnostic - semi-fluid lubrication grease	○	
Steering system		
RB Servocom	●	
Braking system		
EBS (Electronic Braking System), ABS (Anti-Lock Braking System), ASR (Acceleration Slip Regulation)	●	
Suspension levelling system		
ECAS air suspension with leveling and kneeling function	●	

Trollino 24 ● standard
○ option

Bodywork	Body structure	
	stainless steel	●
	Side panels	
	removable side panels	●
	Door arrangement	
		1-2-2-2-0 2-2-2-2-0 1-2-2-2-2 2-2-2-2-2
	Entrance height	
	entrance height for all doors	320 mm
	Wheelchair ramp	
	wheelchair ramp at the 2nd entrance, manually operated	●
wheelchair ramp at the 2nd entrance, electrically operated	○	
Number of passenger seats (depending on door arrangement and batteries)	max. 68	

Heating, ventilation and air-conditioning	Air-conditioning in the driver's cabin	
	air-conditioning powered by passenger compartment unit	○
	air-conditioning with electric drive	○
	Air-conditioning in the passenger compartment	
	air-conditioning with electrical drive	○
	Ventilation system	
dual-function fans	●	
Passenger compartment heating system		
electric 1-stage blowers	○	
water heating, electric water heater TJ40.3 (40 kW), convector-type heaters, 2-stage blowers	●	

Electrical installation	Electric installation	
	electrical installation based on Can-Bus system	●

› Urbino 18 electric

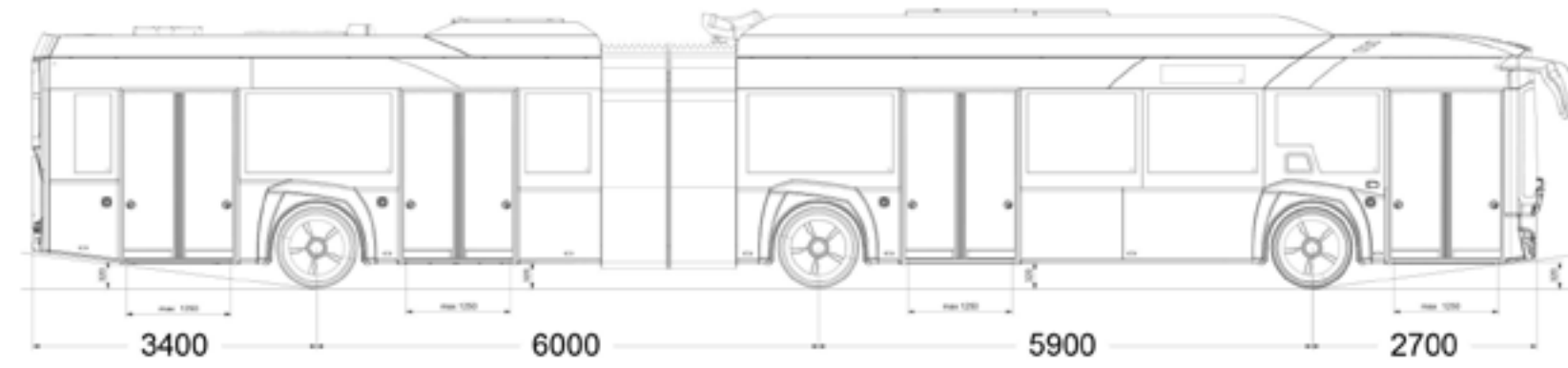

› Urbino 15 LE electric

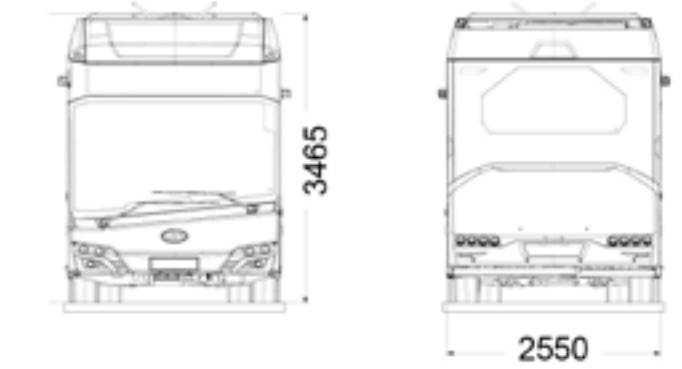
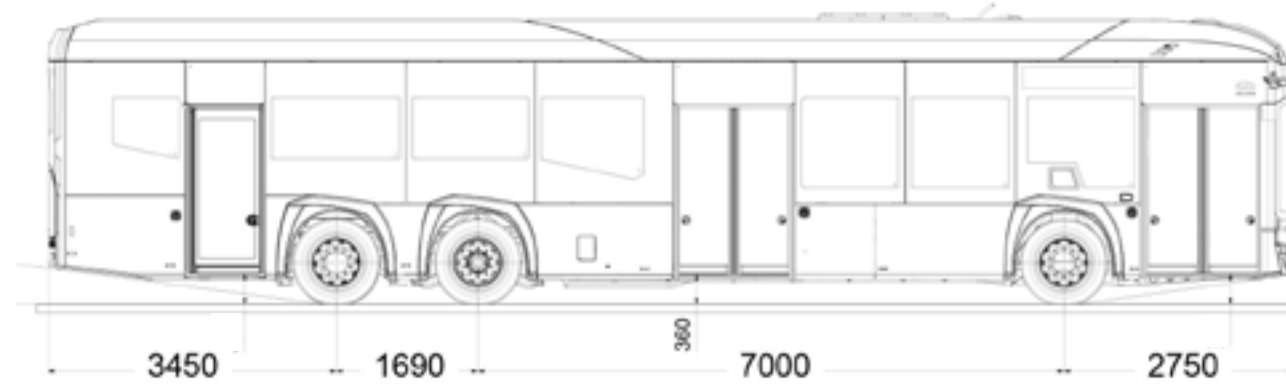

› Urbino 12 electric

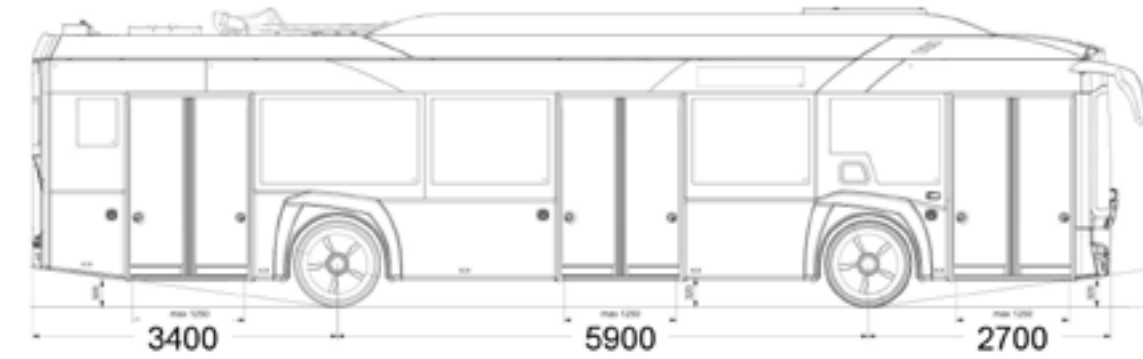

› Urbino 9 LE electric

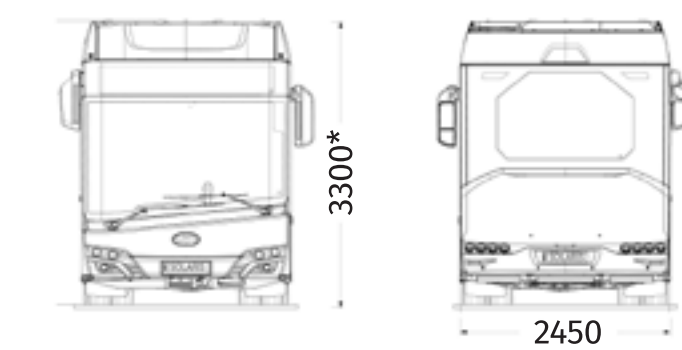
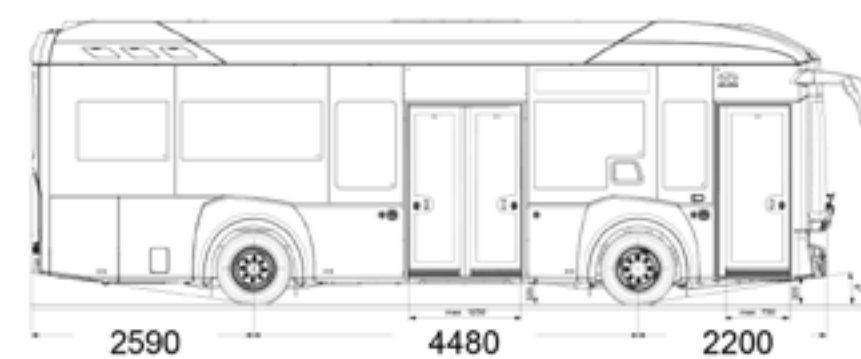

* For wheels 265x70R19.5 - 3300 mm
For wheels 285x70R19.5 - 3315 mm

› Urbino 18 hydrogen



› Urbino 12 hydrogen

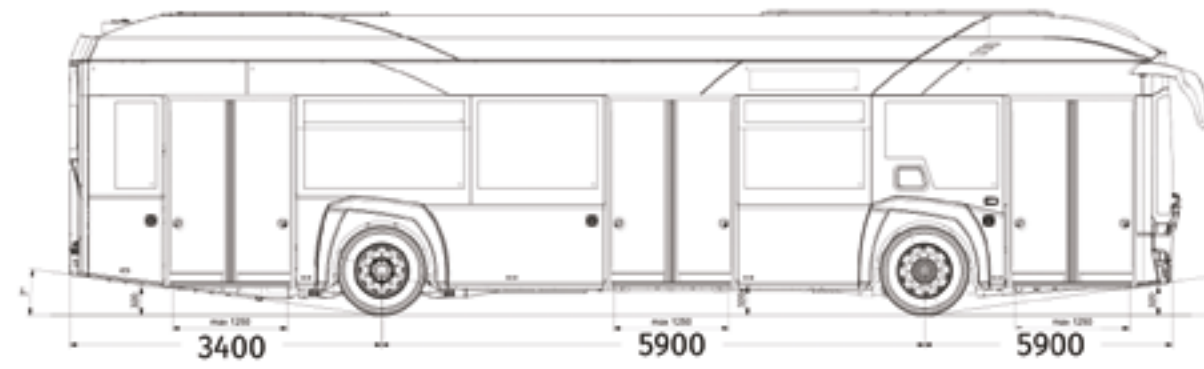

› Trollino 24

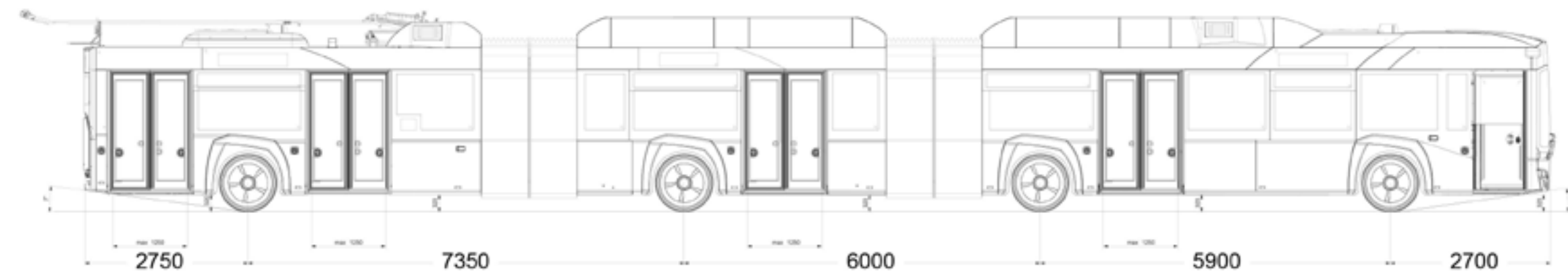

› Trollino 18

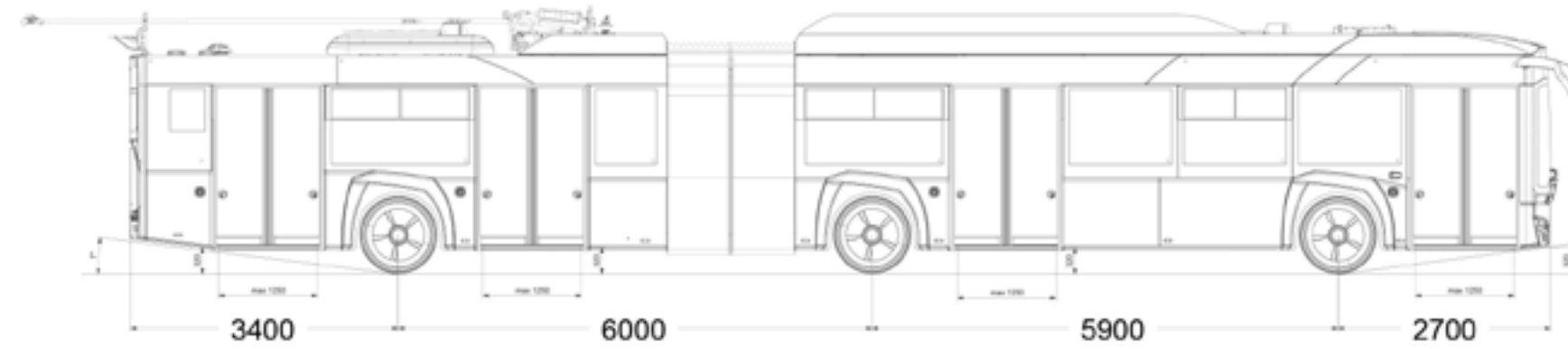

› Trollino 12

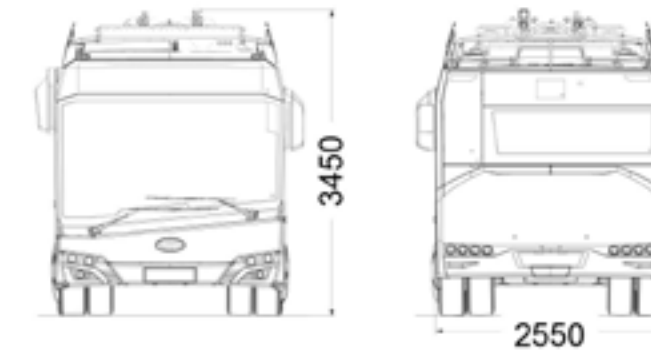
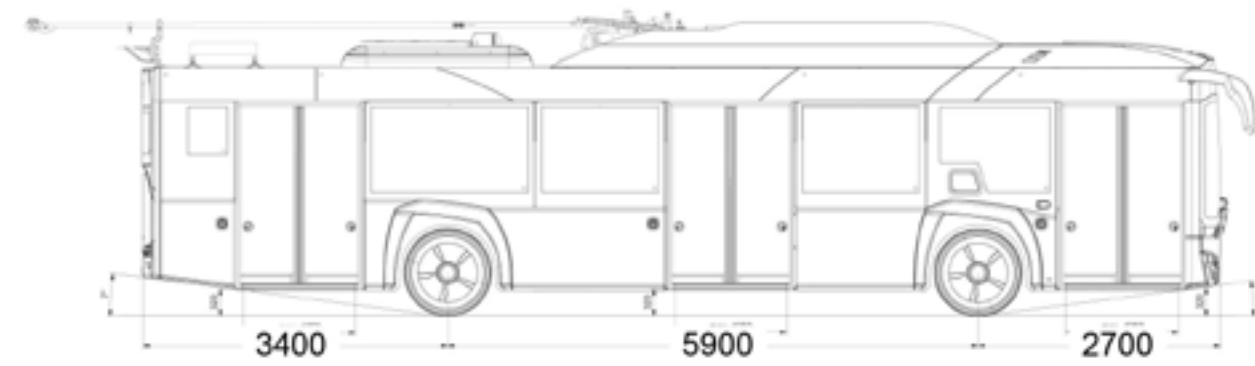

› Trollino 24 Metrostyle

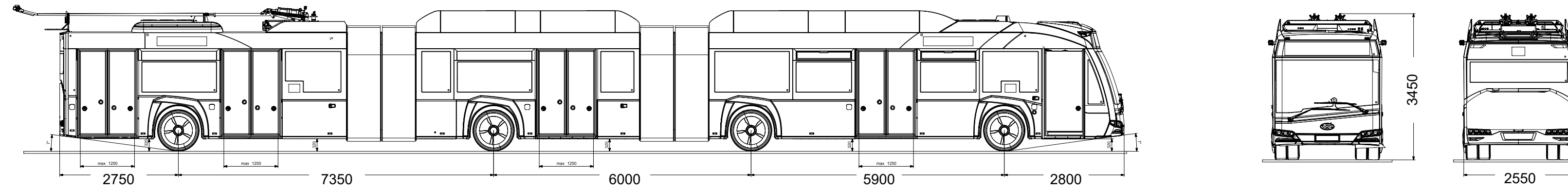

Solaris Urbino 9 LE electric | exhibition vehicle



Solaris Urbino 9 LE electric | exhibition vehicle



Solaris Urbino 9 LE electric | exhibition vehicle



Solaris Urbino 12 electric | exhibition vehicle



Solaris Urbino 12 electric | exhibition vehicle



Solaris Urbino 12 electric | exhibition vehicle



Solaris Urbino 15 LE electric | exhibition vehicle



Solaris Urbino 15 LE electric | exhibition vehicle



Solaris Urbino 15 LE electric | exhibition vehicle



Solaris Urbino 18 electric | exhibition vehicle



Solaris Urbino 18 electric | exhibition vehicle



Solaris Urbino 18 electric | exhibition vehicle



Solaris Urbino 12 hydrogen | exhibition vehicle



Solaris Urbino 12 hydrogen | exhibition vehicle



Solaris Urbino 12 hydrogen | exhibition vehicle



Solaris Urbino 18 hydrogen | exhibition vehicle



Solaris Urbino 18 hydrogen | exhibition vehicle



Solaris Urbino 18 hydrogen | exhibition vehicle



Trollino 12 | Gdynia



Trollino 12 | Gdynia



Trollino 18 | Bergen



Trollino 24 MetroStyle | exhibition vehicle



Trollino 24 MetroStyle | exhibition vehicle



Trollino 24 MetroStyle | exhibition vehicle



Trollino 24 MetroStyle | exhibition vehicle



Solaris Bus & Coach sp. z o.o.
ul. Obornicka 46, 62-005 Owińska, Poland
Tel. +48 61 667 2333, Fax +48 61 667 2310
solarisbus@solarisbus.com, www.solarisbus.com
2023.10