

# KÖGEL

NOVUM: LIGHT & STRONG



**KÖGEL COOL – PURFERRO QUALITY**

# PASSIONEERING FOR OUR CUSTOMERS

What's more exciting than the transport sector? The future of the transport sector! We passionately believe that to stay profitable, you have to stay ahead of the game – and our experience has shown that to be true. Competitive pressure on our customers is building. That's why we want to lighten the load – along with the cargo that you transport with reliable Kögel trailers every day. A close, cooperative partnership with our customers is the starting point of all our innovations. Only then can we quickly identify their changing needs and requirements – and get the right solutions on the road. That's where engineering comes in, which we have loyally practised for over 80 years. Our commitment to uncompromising quality. And, of course, our dedicated professional team.

## **From practice to theory and from plan to practice: Passioneeering never stops.**

All our customers' challenges flow directly into the development process. We subject our innovations to intensive testing, far beyond the usual requirements. Extreme driving manoeuvres, heavy loads, poor road surfaces, rain, ice, snow and scorching sun – our trailers have to withstand it all without a hitch. Only then are we satisfied – for now, at least. Because only then can we be sure that our most discerning customers are satisfied, too. But the end of every development process is only the beginning of something new. After all, everything we do is with the future of the transport sector in mind.

**Find out more about passioneeering and our exceptional quality standards at**  
[www.koegel.com](http://www.koegel.com)

**SAFE**

**KÖGEL COOL .....4 CUSTOMISATION .....6 TRANSPORT OF GOODS .....7**



**SIDE WALLS MADE OF SANDWICH PANELS.....8**    **TECHNICAL DATA.....9**    **QUALITY PROMISE ..... 10**

# KÖGEL COOL – PURFERRO QUALITY

**LIGHTWEIGHT IS THE NEW AWARE  
BECAUSE WE CARE!**



More demanding life-styles and the desire for fresh food on a daily basis have led to a significant growth in the market for both fresh products and frozen foods during the last few years. In order to fully meet the requirements this development has brought about, the transportation logistics industry is faced with a number of challenges: Flexible, durable, yet lightweight refrigerated vehicles that have been adapted to suit special market requirements are in great demand.

## Features:

- ✓ **Excellent insulating properties**
- ✓ **High durability**
- ✓ **Low basic weight**

## Our solution for your industry:

**Frozen and fresh delivery | Ferry/RoRo | Medical products | Safety transports | Plants**

**Side wall**

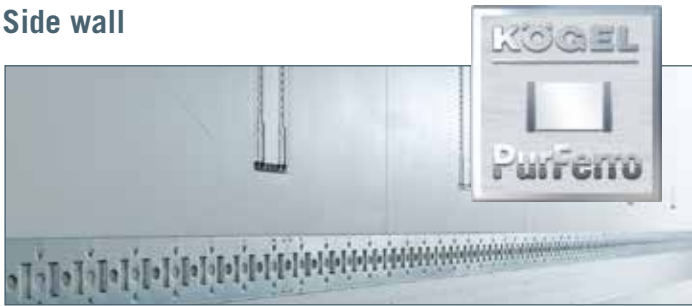

Best insulation with the Kögel PurFerro quality from our in-house competence centre

**Roof**



85 millimetre thick sandwich element with insulating core



Interior lighting: three LED strips with switches on the controllers



**Floor and side protection bar**



High friction value for safety and optimum load-securing

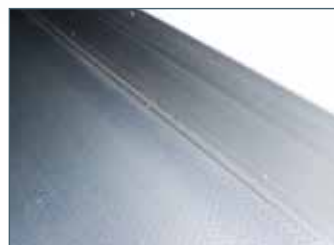

Optimum hygiene and cleaning characteristics

**Portal**



Optimised four-fold lip seal on door to provide secure seal and reduce energy consumption



Stainless steel portal with rotating rods and hinges which are easy to replace

# CUSTOMISATION

With its wide range of different options, the Kögel Cool – PurFerro quality reflects decades of experience and intensive Engineering skills, thus offering everything required of the most discerning market for temperature logistics.

## COUNTRY-SPECIFIC EQUIPMENT

.... 15-tonne fifth-wheel load

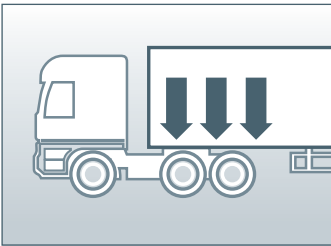

.....Steering axle



... Axle lift for 1st + 3rd axle

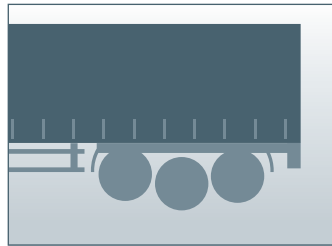

## PROTECTIVE BUMPER RAIL VERSIONS





## SAFE TRANSPORT OF GOODS THROUGH

### air duct (Climatex)



- The elongated, wider air duct ensures that the cooling air is guided and distributed throughout the interior even more effectively.

### Multi-layer loading



- Transport volume increased by 33 Euro pallets thanks to second loading level.
- Aluminium rails for multi-level loading to make it easy to clean the refrigerated semi-trailer.
- Simple to adjust the height of loading bars for varying pallet heights.

### Anchor rails



- The completely recessed anchor rail offers optimum load-securing through the complete load length.

### Impact protection wall



- Optimum protection of front wall and evaporator.
- Designed to be easy to remove with V-shaped aluminium lattices.

# SIDE WALLS OF SANDWICH PANELS

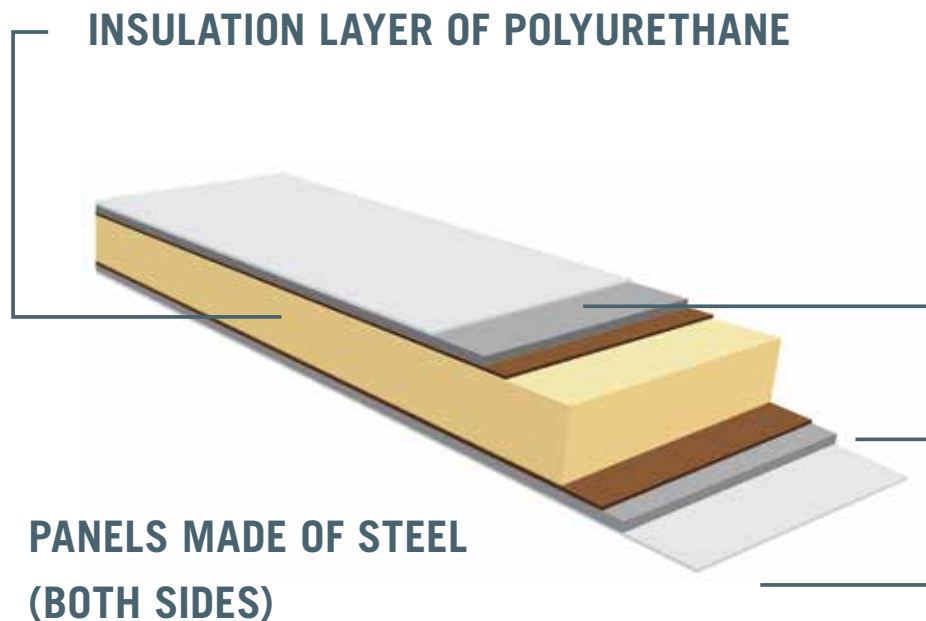

- Side wall made of sandwich elements with insulated core (100% CFC-free)
- Covering layer made of 0.6-millimetre sheet steel end-coated and interior made of 0.6-millimetre sheet steel with hard PVC film coating
- Smooth and food-compatible surface guarantees easy cleaning
- Total wall thickness:  
**approx. 60 mm with type SVT frozen or**  
**approx. 45 mm with type SVA general purpose**



# TECHNICAL DATA

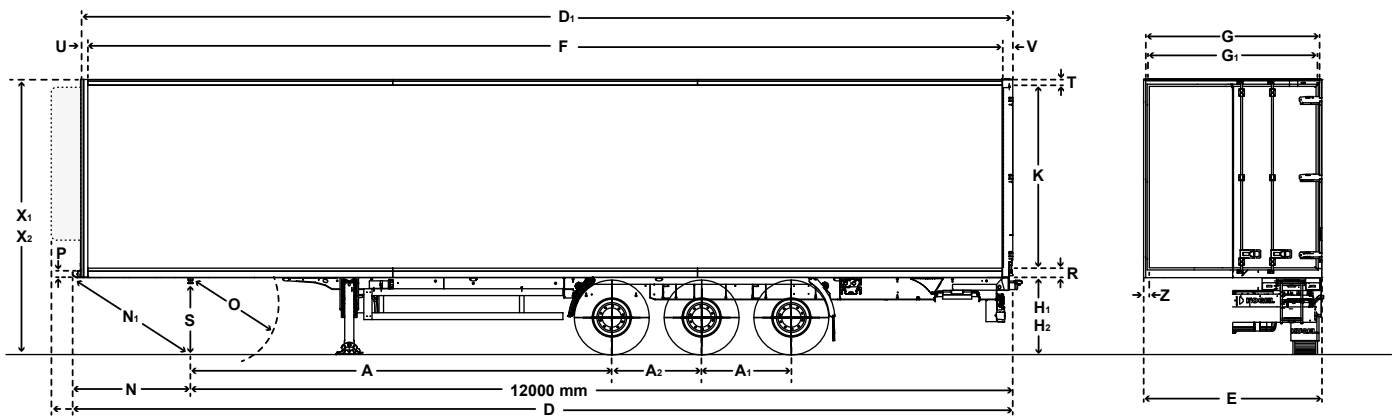

Technically feasible fifth wheel load:	15,000 kg
Technically feasible axle load:	27,000 kg (9,000 kg per axle)
Technically feasible gross weight:	42,000 kg
Floor load-bearing capacity according to EN 283, test axle load	7,200 kg

(A)	Wheelbase:	6,150 mm
(A1)	Distance between axles:	1,310 mm
(A2)	Distance between axles:	1,310 mm
(D)	Total length:	13,730 mm
(D1)	Body length:	13,600 mm
(E)	Total width:	2,600 mm
(F)	Clear loading platform length:	13,325 mm
(K)	Clear height below roof:	2,650 mm
(N)	Front overhang (according to ISO 1726):	1,730 mm
(N1)	Front overhang radius (according to ISO 1726):	2,040 mm
(O)	Slew radius to rear (according to ISO 1726):	2,300 mm

	<b>SVT</b> <b>60-mm side walls</b>	<b>SVA</b> <b>40-mm side walls</b>	
(G)	Clear width of loading platform:	2,470 mm	2,500 mm
(G1)	Clear loading platform width between protective bumpers: approx.	2,460 mm	2,490 mm
	Tare weight basic version:	7,450 kg	7,150 kg

All dimensions stated are approximate

# THE KÖGEL QUALITY PROMISE



## Safety

Complex components guarantee a high degree of active and passive safety: specially developed panelling elements on the frame for improved aerodynamics, underride guard compliant with the new EC Directive, standard load-securing as per EN 12642 XL, RSS for greater driving stability and safety-optimised height adjustment valve (lifting roof with BG support). Kögel trailers also have outstanding trailing characteristics.



## Electronic system and lighting

EBS is fitted as standard. Full LED lighting is available to provide a long life and minimise power consumption.



## Underride guard

All Kögel trailers are equipped with a reinforced underride guard, which significantly increases passive safety in road transport and conforms to EU Directive UN/ECE-R 58.

## Light carrier

The light carrier is made of impact-resistant plastic and provides 100% corrosion protection. It can be installed and replaced separately.



## Corrosion protection

Nano-ceramic plus KTL cathodic dip-paint coating, the most modern and highest quality industrial surface treatment on the market, provides the same outstanding properties as the coating previously applied using zinc phosphate, but it is more environmentally friendly and provides a better energy balance. The durable, clean surface coating can be repainted at any time.



## Service

Visit [www.koegel.com](http://www.koegel.com) to take advantage of our comprehensive services at any time, from anywhere. Repair and warranty services can be managed conveniently online. Our Kögel Hotline Assistance is available around the clock in many European languages.



## Extensive tests

All trailer components are inspected to the highest standards during static and dynamic tests.



## Frame and floor construction

A clever frame design means less weight. All this is paired with a stable sandwich floor, featuring an insulating foam core and wooden cross beams for maximum stability and durability.



## Environmental protection and sustainability

Kögel trailers make an active contribution to reducing fuel consumption and environmental pollution: The aerodynamics are optimised, structural noise emissions are reduced and strict guidelines are observed during production to protect the environment and ensure that the materials used can be recycled.



## Load-securing and body stability

Kögel fulfils all stability requirement for reinforced bodies according to EN 12642 XL. Securing the load on trailers with this certificate is very simple: With a form-locked load, secured at the rear, the body absorbs all forces generated, thanks to the driving dynamics conforming to VDI 2700.





# **KÖGEL**

Kögel Trailer GmbH | Am Kögel-Werk 1 | 89349 Burtenbach | Germany  
Tel +49 8285 88-0 | Fax +49 8285 88-17905 | [info@koegel.com](mailto:info@koegel.com)  
[www.koegel.com](http://www.koegel.com)

Safety note! The trailer may only be used subject to express compliance with all road traffic, employers' liability insurance association and load-securing technology regulations. No liability can be accepted for errors or omissions. We reserve the right to make technical changes. Printed in Germany. Reprinting not permitted 12/21. Order No.: 100-1103-EN